

**Charlotte County Utilities**  
**Manual of Rules and**  
**Regulations Governing**  
**Cross- Connection Control**

**FEBRUARY 2008**

# TABLE OF CONTENTS

## **SECTION 1 - INTRODUCTION**

- 1.1 General

## **SECTION 2 - OVERVIEW**

- 2.1 Purpose
- 2.2 Protection
- 2.3 Elimination of Cross Connections
- 2.4 Cross Connection Control Program

## **SECTION 3 - REGULATIONS , ACTS AND LAWS**

- 3.1 Authority
- 3.2 Safe Water Drinking Act
- 3.3 Florida Regulations
- 3.4 Accepted Practices
- 3.5 Objectives
- 3.6 Responsibility

## **SECTION 4 - DEFINITIONS**

## **SECTION 5 - RECORDS, TESTING , COMPLIANCE**

- 5.1 Records
- 5.2 Test and Maintenance Form
- 5.3 Tester and Equipment Verification

## **SECTION 6 - COMPLIANCE, VIOLATIONS, AND NOTIFICATIONS**

- 6.1 Written Notices
- 6.2 Violations
- 6.3 Fees and Charges

## **SECTION 7 - BACKFLOW AND NON-POTABLE FLUIDS**

- 7.1 Policy
- 7.2 Inspections
- 7.3 Auxiliary Water Supply
- 7.4 Industrial Fluids
- 7.5 Installation
- 7.6 Internal Cross- Connection
- 7.7 Supply Line Connections

## **SECTION 8 - REQUIRED BACKFLOW PROTECTION**

- 8.1 Degree of Hazard
- 8.2 Hazards of Backflow
- 8.3 Procedure Low Hazard
- 8.4 Procedure High Hazard
- 8.5 Non- Potable Supply
- 8.6 Objectionable Non- Hazardous
- 8.7 Actual or Potential Hazard
- 8.8 Facilities Backflow Requirements\
- 8.9 Actual or Potential Cross-Connections
- 8.10 Restricted Premises
- 8.11 Commercial Customers
- 8.12 Residential Customers
- 8.13 Tank Filling

## **SECTION 9 - APPROVED BACKFLOW ASSEMBLY**

## **SECTION 10 - REPAIRS AND TESTING**

- 10.1 Testing of Backflow Assemblies
- 10.2 Repairs of Backflow Assemblies
- 10.3 Records and Reports
- 10.4 Repairs
- 10.5 Test Failure

## **SECTION 11 - INSTALLATION**

- 11.1 Installation Guidelines
- 11.2 Location of Backflow

## **SECTION 12 - RECLAIMED WATER**

- 12.1 Supply
- 12..2 Blow-offs
- 12.3 Fire Protection
- 12.4 Irrigation Specifications
- 12.5 Wells and Prohibited Connections
- 12.6 Cross-Connection Procedure

## **SECTION 13 - THERMAL EXPANSION**

- 13.1 Thermal Expansion
- 13.2 Testing
- 13.3 Symptoms of Thermal Expansion
- 13.4 Expansion Tanks

**APPENDIX A** Notices and Reports

**APPENDIX B** Standard Drawing Details

# CHARLOTTE COUNTY UTILITIES' MANUAL OF CROSS- CONNECTION CONTROL

## SECTION 1 - INTRODUCTION

Section 3-8-202 of the Charlotte County Code, contained within Chapter 3-8, Article VI titled "Reclaimed Water System" references the County's " Rules and Regulations Governing Cross-Connection Control " manual. This applies to the most current version of the manual, as promulgated and subsequently updated by Charlotte County Utilities.

This "Manual of Rules and Regulations Governing Cross Connection Control " has been prepared by the Utilities Department of Charlotte County Florida to insure the safety of the potable water system and to establish an effective cross-connection program in accordance with directives issued at the Federal and State level. This manual provides the rules, regulations, specifications and procedures necessary to administer the backflow program and facilitate compliance of the aforementioned Federal and State laws, statutes and regulations.

### 1.1 Charlotte County Utility:

- A. Requires the review of this manual before designing a project or installing a cross connection control device,
- B. Believes the material in this manual will provide the Customer with the understanding of cross-connections and cross connection control assemblies,
- C. Will insure that the standards and specifications as set forth in this manual will be uniformly enforced,
- D. Reserves the right to update this manual as necessary due to changes in FDEP policies and regulations and/or USC Foundation for Cross- Connection Control and Hydraulic Research or AWWA standards.

## **SECTION 2 – OVERVIEW**

### **2.1 The purpose of a Cross Connection Control Program is to;**

- A. Protect the potable water supply of Charlotte County from the possibility of contamination or pollution,
- B. Eliminate cross-connection, and
- C. Maintain a cross-connection and backflow program.

### **2.2 Protection and Reclaimed Water**

Community water systems, and all public water systems which have service areas that are also served by reclaimed water systems as defined in Chapter 62-610, Part III, F.A.C., shall establish a routine cross connection control program to detect and prevent cross connections that create or may create an imminent and substantial danger to public health. This program shall include a written plan that is developed using accepted practices of the American Water Works Association as set forth in the reference documents cited in Rules 62-555.330(6) and (7), F.A.C. (Ref.: F.A.C. Chapter 62-555.360 or latest edition.)

### **2.3 Elimination of Cross Connections**

The purpose of the Cross Connection Control Program is to promote the elimination and control of cross connections (actual or potential) between potable water system(s), non-potable water system(s), and plumbing fixture(s) in existing commercial and/or residential buildings.

### **2.4 Cross Connection Control Program**

The Cross Connection Control Program provides for the management and operation of a continuing program of cross connection control which will systematically and effectively prevent the contamination or pollution of the County's water distribution system, as required by F.A.C. Chapter 62-555.360

## **SECTION 3 – REGULATIONS, ACTS, LAWS**

The following authorities are justification in establishing a Cross Connection Control Program.

### **3.1 Safe Drinking Water Act**

The Safe Drinking Water Act (PL 93-523) was signed into law by Congress on December 16, 1974. The purpose of the law is to assure that the Nation's potable water supply systems serving the public meet minimum National Health Standards for the protection of the public health.

In accordance with the Safe Drinking Water Act, the National Interim Primary Drinking Water Regulations were promulgated on December 24, 1975, and became effective on June 24, 1977. These regulations replaced the Public Health Service Drinking Water Standards of 1962. Appendix "A" states that the "minimum protection should include programs that result in ... prevention of health hazards, such as cross-connections."

The Safe Drinking Water Act and its Regulations cover all public water systems with piped water for human consumption with at least 15 service connections or a system that regularly serves 25 individuals. Under Section 1413 of the Safe Drinking Water Act, states can obtain primary 2.1.1 enforcement responsibilities for their water quality program. However, the state's regulations must be equal to or exceed the federal regulations. The Administrator of the Environmental Protection Agency retains authority over states that do not obtain primacy.

### **3.2 Florida Regulations**

The State of Florida was granted primacy over the water program under the authority of the "Florida Safe Drinking Water Act" Chapter 403.850-403.864 Florida Statutes. In January 1975, the State of Florida adopted Florida Administrative Code Chapter 17-22 (Public Drinking Water Systems) and the regulations went into effect in November 1977. The Florida regulations were revised in November 1987 to address the topic of cross-connection control and backflow prevention and incorporated more specific language than what is contained in the federal regulation. The Florida regulations (Chapter 17-22, F.A.C.) were revised again, and renumbered in December 1996 as Florida Administrative Codes 62-550, 62-555, and 62-560.

"Cross Connection" "means any physical arrangement whereby a public water supply is connected, directly or indirectly, with any other water supply system, sewer, drain, conduit, pool, storage reservoir, plumbing fixture, or other device which contains or may contain contaminated water, sewage or other waste, or liquid of unknown or unsafe quality which may be capable of imparting contamination to the public water supply as the result of backflow. Bypass arrangements, jumper connections, removable sections, swivel or changeable devices, and other temporary or permanent devices through which or because of which backflow could occur are considered to be cross connections."

Rule 62-555.360(1), F.A.C. states that “Cross connection as defined in Rule 62-550.200 F.A.C. is prohibited.”

Under Rule 62-555.360(2), revised in the year 2003, “Community water systems ... shall establish and implement a routine cross connection control program to detect and prevent cross connection that create or may create an imminent and substantial danger to the public health.”

Upon discovery of a prohibited cross connection, public water systems shall either eliminate the cross connection by installation of an appropriate backflow prevention device acceptable to the Department or shall discontinue service until the contaminant source is eliminated.

### **3.3 Local Enforcement**

As the water purveyor, the Charlotte County Utilities Cross Connection Control Program is based on the guidelines set down in Rule 62-555.360 F.A.C.

### **3.4 Accepted Practices**

Such a program shall be developed utilizing accepted practices of the American Water Works Association as guidelines as set forth in AWWA Manual M14, “Recommended Practice for Backflow Prevention and Cross Connection Control” (3<sup>rd</sup> edition), AWWA Manual “Cross Connection and Backflow Prevention” (2<sup>nd</sup> edition) (F.A.C. 62-555.360), The EPA Cross Connection Control Manual and the USC Cross Connection Manual of Cross-Connection Control (latest edition).

### **3.5 Objectives**

Backflow may result in the potable water system becoming a transmitter of diseases, and/or toxic materials and other hazardous liquids. Therefore, it is necessary to establish and maintain a Cross Connection Control Program to protect the health of the Charlotte County water system customers and/or users of the potable water system by the control of actual or potential cross-connections through methods of containment and/or isolation.

### **3.6 Responsibility**

Charlotte County Utilities and Building Construction Services as well as the utility customers share the responsible for the protection of the potable water distribution system from contamination or pollution due to the backflow of contaminants or pollutants through any and all water service connections. Charlotte County shall require an approved backflow prevention assembly installed at the water service connection to all consumer’s premises.

Charlotte County Utilities will designate the location of all the backflow prevention assemblies. Failure, refusal, or inability on the part of the consumer to install a backflow assembly shall constitute grounds for refusal of water or the discontinuance of water to the premises until such an assembly or assemblies have been properly installed.

Records of backflow prevention assemblies will be maintained by Charlotte County Utilities.

## SECTION 4 DEFINITIONS

### 1. Air Gap Separation

The term "Air-Gap Separation" shall mean a physical separation between the free flowing discharge end of a potable water supply pipeline and an open or non-pressure receiving vessel. An "approved air-gap separation" shall be at least double the diameter of the supply pipe measured vertically above the overflow rim of the vessel – in no case less than 1 inch (2.54 cm).

### 2. Approved

The term "approved" as herein used in reference to air-gap separation, a double check valve assembly, a reduced pressure principle backflow prevention assembly or other backflow prevention assemblies or methods shall mean approval by the Director of Utilities or his/her designee.

### 3. Approved Backflow Prevention Assembly

The term "approved backflow prevention assembly" shall mean an assembly that has been manufactured in full conformance with American Water Works Association (AWWA) Standards. Backflow prevention assemblies must also meet the laboratory and field performance specifications of the Foundation for Cross Connection Control and Hydraulic Research of the University of Southern California.

### 4. Approved Check Valve

The term "approved check valve" shall mean a check valve that is drip-tight in the normal direction of flow when the inlet pressure is at least 1 psi and the outlet pressure is zero. The check valve shall permit no leakage in a direction reverse to the normal flow. The closure element (e.g., clapper, poppet, or other design) shall be internally loaded to promote rapid and positive closure. An approved check valve is only one component of an approved backflow prevention assembly (i.e., pressure vacuum breaker, double check valve assembly, or reduced principal assembly).

### 5. Atmospheric Vacuum Breaker

The term "Atmospheric Vacuum Breaker" shall mean a backflow prevention assembly operated by atmospheric pressure in combination with the force of gravity. The unit is designed to work on a vertical plane only. The one moving part consists of a poppet valve which must be carefully sized to slide in a guided chamber and effectively shut off the reverse flow of water when a negative pressure exists.

### 6. Backflow

The term "backflow" shall mean the undesirable reversal of flow of water or mixtures of water and other liquids, gases or other substances into the distribution pipes of the potable supply of water from any source or sources.

### 7. Backflow Prevention Assembly – Type

A "backflow prevention assembly" shall mean any effective assembly used to prevent backflow into a potable water system. The type of assembly used should be based on the degree of hazard either existing or potential. The types are:

- A. Double Check Valve Assembly
- B. Double Detector Check Valve Assembly
- C. Pressure Vacuum Breaker
- D. Reduced Pressure Principle Assembly

**8. Back Pressure**

“Back-Pressure” shall mean any elevation of pressure in the downstream piping system (by pump, elevation or piping, or stream and/or air pressure) above the supply pressure at the point of consideration which would cause, or tend to cause, a reversal of the normal direction of flow through the backflow prevention assembly.

**9. Back-Siphonage**

“Back-Siphonage” shall mean a form of backflow due to a reduction in system pressure which causes a negative or sub-atmospheric pressure to exist at a site in the water system.

**10. Certified Backflow Prevention Assembly Tester**

“Certified Backflow Prevention Assembly Tester” shall mean a person who can prove competency to the satisfaction of Charlotte County Utilities (proof may be required). The tester shall have attended and successfully completed an approved course for Backflow Prevention Assembly Testers, or other programs or training acceptable to Charlotte County Utilities.

**11. Charlotte County Utilities**

“Charlotte County Utilities” shall mean the Director or his Designee who is vested with the authority and responsibility for the implementation of an effective Cross Connection Control Program and the enforcement of the provisions of this ordinance.

**12. Consumer**

The term “consumer” shall mean the owner or operator of a private plumbing and/or water system who receives water from the Charlotte County water system.

**13. Contamination**

“Contamination” shall mean an impairment of the quality of the water which creates an actual hazard to the public health through poisoning or through the spread of disease by sewage, industrial fluids or waste.

**14. Cross-Connection**

A “cross connection” shall mean any unprotected actual or potential connection or structural arrangement between a public or a consumer’s potable water system and any other source or system through which it is possible to introduce into any part of the potable system any used water, industrial fluid, gas, or substance other than the intended potable water with which the system is supplied. By-pass arrangements, jumper connections, removable sections, swivel or change-over assemblies and other temporary or permanent assemblies through which or because of which “backflow” can or may occur are considered to be cross connections.

## **15. Cross-Connection Control**

“Cross Connection Control” shall mean control of connection between a potable water system and a non-potable plumbing and/or water system by proper installation of approved backflow prevention assembly that will continuously protect the potable water system.

## **16. Double Check Valve Assembly**

An assembly composed of two single, independently acting, check valves, including tightly closing shutoff valves located at each end of the assembly and suitable connections for testing the water tightness of each check valve. A check valve is a valve that is drip-tight in the normal direction of flow when the inlet pressure is one psi and the outlet pressure is zero. The check valve shall permit no leakage in a direction reverse to the normal flow. The closure element (e.g., clapper) shall be internally weighted or otherwise internally loaded to promote rapid and positive closure.

## **17. Double Detector Check Valve Assembly**

The term “Double Detector Check Valve Assembly” shall mean a specifically designated assembly composed of a line size approved double check valve assembly with a specific bypass water meter and a meter sized approved double check valve assembly. The meter shall register accurately for only very low rates of flow and shall show a registration for all rates of flow. This assembly shall only be used on fire lines to protect against a non-health hazard (i.e., pollutant).

## **18. Hazard, Degree of**

The term “Degree of Hazard” shall be derived from the evaluation of conditions within a system which can be classified as either a “pollutional” (non-health) or a “contamination” (health) hazard.

## **19. Hazard – Health**

The term “Health Hazard” shall mean an actual or potential threat of contamination of a physical or toxic nature to the public potable water system or the consumer’s potable plumbing and/or water system that would be a danger to health.

## **20. Hazard – Plumbing**

The term “Plumbing Hazard” shall mean an internal or plumbing type cross connection in a consumer’s potable water system that may be either a pollutional or a contamination type hazard. This includes but is not limited to cross connections to toilets, sinks, lavatories, wash-trays, domestic washing machines and lawn sprinkling systems. Plumbing type cross connections can be located in many types of structures including homes, apartment houses, hotels, and commercial or industrial establishments. Such a connection must be properly protected by an appropriate type of cross connection assembly.

## **21. Hazard – Pollutional**

The term “Pollutional Hazard” shall mean an actual or potential threat to the physical properties of the water system or the potability of the public or the consumer’s potable water system but which would not constitute a health or system hazard, as defined. The maximum degree or intensity of pollution to which the potable water system could be degraded under this definition would cause a nuisance or be aesthetically objectionable or could cause minor damage to the system or its appurtenances.

## **22. Industrial Fluids**

The term “Industrial Fluids” shall mean any fluid or solution which may be chemically, biologically or otherwise contaminated or polluted in a form or concentration such as would constitute a

health, system, pollutorial, or plumbing hazard if introduced into an approved water supply. This may include, but not be limited to; polluted or contaminated used water; all types of process waters and “used waters” originating from the public potable water system which may deteriorate in sanitary quality; chemicals in fluid form; plating acids and alkalies; circulated cooling waters connected to an open cooling tower and/or cooling waters that are chemically or biologically treated or stabilized with toxic substances; contaminated natural waters such as from wells, springs, streams, rivers, bays, harbors, seas, irrigation canals or systems, etc.; oil, gasses, glycerine, paraffin, caustic and acid solutions and other liquid and gaseous fluids used in industrial or other processes or for fire fighting purposes.

### **23. Industrial Piping System – Consumer’s**

The term “Consumer’s Industrial Piping System” shall mean any system used by the consumer for transmission of or to confine or store any fluid, solid or gaseous substance other than an approved water supply. Such a system would include all pipes, conduits, tanks, receptacles, fixtures, equipment and appurtenances used to produce, convey or store substances which are or may be polluted or contaminated.

### **24. Laboratory – Approved Testing**

Reference to an “Approved Testing Laboratory” shall mean the foundation for Cross Connection Control and Hydraulic Research of the University of Southern California or another laboratory having equipment capabilities for both the laboratory and field evaluation of the assemblies.

### **25. Pollution**

The term “Pollution” shall mean an impairment of the quality of the water to a degree which does not create a hazard to the public health but which does not adversely and unreasonable affect the aesthetic qualities of such waters for domestic use.

### **26. Pressure Vacuum Breaker & Atmospheric Vacuum Breaker**

The term “Pressure Vacuum Breaker” shall mean an assembly containing an independently operating internally loaded check valve and an independently operating loaded air inlet valve located on the discharge side of the check valve. The assembly is to be equipped with properly located test cocks and tightly closing shut-off valves attached at each end of the assembly. This assembly is designed to protect against a health hazard (i.e., contaminant) under a back-siphonage condition only. A pressure vacuum breaker is similar to an atmospheric vacuum breaker except that the checking unit “poppet valve” is activated by a spring. This type of vacuum breaker does not require a negative pressure to react and can be used on the pressure side of a valve.

The term “Atmospheric Vacuum Breaker” shall mean a backflow prevention assembly operated by atmospheric pressure in combination with the force of gravity. The unit is designed to work on a vertical plane only. The one moving part consists of a poppet valve which must be carefully sized to slide in a guided chamber and effectively shut off the reverse flow of water when a negative pressure exists.

### **27. Reduced Pressure Principle Backflow Prevention Assembly**

The term “Reduced Pressure Principle Backflow Prevention Assembly” shall mean an assembly containing two independently acting approved check valves together with a hydraulically operating, mechanically independent pressure differential relief valve located between the check valves and at the same time below the first check valve. The unit shall include properly located test cocks and tightly closing shut off valves at each end of the assembly. This assembly is designed to protect against a health hazard (i.e., contaminant).

### **28. Service Connection**

The term “Service Connection” shall mean the terminal end of a service connection from the public potable water system, i.e., where the water purveyor may lose jurisdiction and sanitary control over the water at its point of delivery to the consumer’s water system. If a meter is installed at the end of the service connection, then the service connection shall mean the downstream end of the meter.

**29 Thermal Expansion**

Thermal expansion is the tendency of matter to increase in volume or pressure when heated. In water systems damage may occur if there is not a method to relieve the pressure.

**30. Water – Potable**

The term “Potable Water” shall mean any water which according to recognized standards is safe for human consumption.

**31. Water Purveyor**

The term “Water Purveyor” shall mean any public potable water supply which has been investigated and approved by the State of Florida Department of Environmental Protection. The system must be operating under a valid permit.

**32. Water Supply – Approved**

The term “Approved Water Supply” shall mean any public potable water supply which has been investigated and approved by the State of Florida Department of Environmental Protection.

**33. Water Supply – Auxiliary**

The term “Auxiliary Water Supply” shall mean any water supply on or available to the premises other than the purveyor’s approved public potable water supply which may be used for residential irrigation or commercial uses including irrigation. These auxiliary waters may include water from another purveyor’s public potable water supply or any natural source such as a well, spring, river, stream, harbor, etc., or “reused wastewater” or “industrial fluids”. Any such water supply may be polluted or contaminated or may be objectionable and constitute an unacceptable water source over which the primary water purveyor does not have sanitary control.

**34. Water Supply – Unapproved**

The term “Unapproved Water Supply” shall mean a water supply which has not been approved for human consumption by the State of Florida Department of Environmental Protection and/or is not operating under a valid permit.

**35. Water System(s) – Consumer’s**

The term “Consumer’s Water System(s)” shall include any plumbing and/or water system located on the consumer’s premises whether supplied by a public potable water system or an auxiliary water supply. The system or systems may be either a potable water system or an industrial piping system.

**36 Water System – Consumer’s Potable**

The term “Consumer’s Potable Water System” shall mean that portion of the privately owned potable plumbing and/or water system lying between the point of delivery and the point of use.

This system will include all pipes, conduits, tanks, receptacles, fixtures, equipment and appurtenances used to produce, convey, store or utilize the potable water.

### **37. Water System – Public**

The term “Public Water System” shall mean the Charlotte County water system operated as a public utility under a valid permit to supply potable water for domestic purposes. This system will include all sources, facilities and appurtenances between the source and the point of delivery such as valves, pumps, pipes, conduits, tanks, receptacles, fixtures, equipment and appurtenances used to produce, convey, treat or store a potable water for public consumption of use.

## **SECTION 5 - RECORD KEEPING AND TESTING**

### **5.1 Record Keeping**

Records concerning installation and testing shall be kept by Charlotte County Utilities for a period not less than ten (10) years. The record for each site shall include the following information:

- A. Information on the primary backflow preventer installed at the site including type, size, manufacturer, model number location, and serial number,
- B. Information on the site including owner’s name, business name, site address, Mailing address and premise number.
- C. A copy of the “Test and Maintenance Reports” including initial test, yearly test, repair reports and tests following repairs.
- D. Any reports of problems associated with the primary backflow preventers or cross-connections at the site.
- E. Results of the cross-connection surveys
- F. Reports of cross-connections and the action taken as a result of the cross- connection including but not limited to notices of violation.

## 5.2 Test and Maintenance Form

The Consumer shall insure that within 30 days of placing an assembly in service, or the test or repair of a backflow prevention assembly, a report is provided to:

Charlotte County Utilities  
Water Quality Control Unit  
25550 Harbor View Road, Unit 1  
Port Charlotte, Florida 33980

The form may be provided by the Charlotte County Utilities or another source as long as all the required information is included. The form titled "Test and Maintenance Report " is included in Appendix A.

The report shall provide the following information as appropriate for the work performed:

1. Street address where assembly is located
2. Name of Owner
3. Type and size of assembly
4. Date of report
5. New installations:
  - a. Date of installation
  - b. Name of manufacturer, and model and serial numbers of assembly
  - c. Sketch of the site showing location of the assembly
  - d. Installer's company name and address
6. Initial test:
  - a. Date of test
  - b. Test results
  - c. Testers' name and certification number
  - d. Testers' company name and address
7. Repair report:
  - a. Date of repair
  - b. Test results before and after repair
  - c. Testers' name and certification number
  - d. Testers' company name and address

### **5.3 Tester and Equipment Verification**

Testers will be required to supply the following information:

A. Copies of their certificates, or cards showing their certification number to Charlotte County Utilities,

B. The most recent calibration of test gauges.

The gauges should be tested annually and the tester's recertification will be determined by the organization that supplied the training. The information should be sent to the address in subsection 5.2.

C. Charlotte County will maintain a list of certified backflow testers and use that information to check the qualifications of the tester submitting each test report.

## **SECTION 6 COMPLIANCE, VIOLATIONS AND NOTIFICATIONS**

### **6.1 Written Notices**

Charlotte County will provide notices to its customers to keep them updated on actions that are necessary for them to be in compliance with the rules and regulations contained within this manual, the Florida Plumbing Code, and all other applicable State and Federal guidelines. The notices will include the following:

#### **A. Notice to Install and Test a Backflow Assembly**

Upon receipt of a written notice from Charlotte County that an approved backflow prevention assembly is required at the water connection to any customer's point of delivery, the customer shall:

1. Install an approved assembly at customer's expense within 60 days of this notice. A temporary water service connection requires an approved backflow preventer installed at the customer's expense,
2. Have a certified backflow tester complete a test of the newly installed backflow and send the completed "Test and Maintenance Report" to the address in Section 5.2 within 30 days of the installation,
3. Request an extension of the time frame for installation of the assembly. The extension will not be considered if the site is rated as high hazard. The extension may be granted for situations created that were beyond the control of the customer including weather, construction delays, lack of certified testers, equipment shortages or related problems.
  - A copy of the notice is included in Appendix A.

## **B. Notice to Have a Backflow Assembly Tested**

A written notice will be sent to customers to have an annual test completed on their backflow assembly. Upon receipt of the notice the customer shall:

1. Have a certified backflow tester complete test the backflow and send a completed "Test and Maintenance Report" to the Water Quality Control Unit at the address in section 5.2
2. Have the backflow repaired or replaced if it fails the testing
3. Have the repairs completed by an individual who is;
  - a. Certified in backflow repair by the organizations accepted by the FDEP.
  - b. Holds a current certificate as a master plumber
  - c. Holds a license as a plumber and works under the supervision of a master plumber.
4. Have the backflow retested and have the results along with the repair Information sent to the Water Quality Control Unit.

## **C. Notice of Violation**

A written notice of violation will be sent to customers who do not respond to the Notice to Install or Notice to Test in a timely manner. The Notice of Violation will be sent to the customer by certified mail The packet will include a letter and the notice. Customers will be required to:

1. Respond to the notice in writing , by phone or e-mail
2. Comply with the notice by correcting the violation
3. Send all test and repair results to the Water Quality Control Unit.

## **6.2 Violations**

Submission by any person of any false statement or representation in any application, record, report, plan, or other document files, required by the policies included in this manual shall be in violation. Any person who has not complied with Federal, State and Local laws or Ordinances shall be in violation. Any person not complying with the Charlotte County Utilities Cross Connection Control Manual shall be in violation.

## **6.3 Fees and Charges**

The county shall have the right in instances of non-compliance, including failure to test, repair, replace, or install the proper backflow preventers, to perform the required service and bill the consumer accordingly.

The fees and charges that the county shall assess the consumer to carry out the provisions of this manual shall be based on;

1. Charlotte County Utilities' current established labor rate.
2. Cost of materials.
3. Fines, fees, and charges are established by County Resolution.

# **SECTION 7 BACKFLOW AND NON-POTABLE FLUIDS**

## **7.1 Policy**

No water service connection to any premises shall be installed or maintained by Charlotte County Utility unless the water supply is protected as required by State of Florida Regulations and Plumbing Code, Charlotte County Codes, and the rules and regulations included in this manual.

Service of water to any premises shall be discontinued by the Charlotte County Utility if a backflow prevention assembly required by this policy is not installed, tested, and maintained,

or if it is found that a backflow prevention assembly has been removed, by passed, or an unprotected cross connection exists on the premises. Service shall not be restored until such condition, or defects are corrected at the consumer's expense.

## **7.2 Inspections**

The Consumer's system shall be open for inspection at all reasonable times to Authorized representatives of Charlotte County Utilities to determine whether actual or potential cross connections exist. When an actual cross connection condition becomes known that presents an immediate "High Health Hazard" Charlotte County Utilities authorized representative shall deny or immediately discontinue service, upon notice to consumer, to the premises and by providing a physical break in the service line until the customer has corrected the conditions to comply with State Statutes relating to plumbing and water supplies, and this adopted policy. Any cost in disconnection or re-connection of the water service will be paid by the consumer.

## **7.3 Auxiliary Water Supply**

The public water system shall be protected against backflow and back siphonage by the installation of an approved backflow prevention assembly, if an auxiliary water supply of unknown bacteriological or chemical quality is found on the consumer's premises.

## **7.4 Industrial Fluids**

If any industrial fluids or any other objectionable substances are handled in such a fashion as to create an actual or potential hazard to the public water system, the public water system shall be protected against backflow and back-siphonage from the premises by the installation of a backflow prevention assembly in the service line appropriate to the degree of hazard. This shall include the handling of process water and waters originating from the utility system, which have been subject to deterioration in quality.

## **7.5 Installation – Retrofit or New**

Backflow prevention assemblies shall be installed at the direction of the Director of Utilities or his/her designated representative at the consumer's meter, property line of a consumer, or at a designated location for any existing facility that needs to be retrofitted. New installations may be installed at the meter or adjacent to a building. Pipe between the meter and backflow preventer shall be type L (hard) copper, K copper, or brass. Cost of retrofitting or new installation of backflow preventers is the responsibility of the consumer.

## **7.6 Internal Cross Connections**

Whenever piping and/or plumbing is undefined or where entry or accessibility to all or portions of the premises is not readily available for inspection purposes, a cross connection situation is presumed and thus prohibited. The public potable water supply system shall be protected at all times against backflow and back siphonage from the premises by the installation of a reduced pressure principal backflow prevention assembly in the service line.

## **7.7 Supply Line Connections**

No plumbing connections of any kind shall be permitted on the pipe between the water meter and the primary backflow preventer. This includes any temporary connections or irrigation systems. Upon discovery of such a connection a notice of violation shall be issued along with the appropriate action. This action will reflect the potential for a high health hazard and will follow the procedures for this hazard level.

## **SECTION 8 Required Backflow Protection**

### **8.1 Degree of Hazard**

The type of protective assembly required shall depend upon the degree of hazard.

The following sections will serve as a guideline for selection of the appropriate backflow preventer. Consumers are encouraged to consider the option of a higher level of protection if the potential for cross-connection exists.

### **8.2 The Hazards of Backflow**

The hazards of backflow can be classified into 4 categories:

<b>Category</b>	<b>Health Hazard</b>
1. Chemical Pollutants	Low
2. Chemical Contaminant	High
3. Biological Pollutants	Low
4. Biological Contaminants	High

Chemical and Biological Pollutants, which are low health hazard will be identified as Type "P". Chemical and Biological Contaminants, which are high health hazard will be identified as Type "C". Additional information on backflow health hazards is in Section 7

### **8.3 Procedure for Chemical or Biological Pollutants – Low Health Hazard**

Upon discovery of a violation that does not present an immediate hazard to the public water supply, written notice thereof shall be given to the consumer. The notice (included in Appendix A) shall be delivered to the premises and a copy mailed to the billing address as registered on the water purveyors' billing records. The notice shall state:

- A. Date and time violation was noted.
- B. The conditions or defects that must be corrected.

- C. How the stated condition(s) are to be corrected.
- D. Recommended date for re-inspection
- E. The date on or after delivery of water may be discontinued, shall not be less than thirty (30) nor more than sixty (60) days following the date of delivery or mailing of the notice. The water purveyor may grant the consumer an extension of an additional thirty (30) days if the water purveyor determines the consumer has been unable to comply with the notice within the time originally allowed but progress had been made in correcting the situation.

#### **8.4 Procedure for Chemical or Biological Contaminants --- High Health Hazard**

Service of water to any premise deemed as an immediate high health hazard to the public water supply shall be disconnected by personnel of Charlotte County Utilities;

- A. If a backflow prevention assembly required by law, rules or regulations is not installed, tested and maintained;
- B. If it is found that a backflow prevention assembly has been removed, damaged, tampered with or by-passed;
- C. If unprotected cross-connections exist on the premises and there is inadequate backflow protection at the service connection.

Water service will not be restored until such conditions or defects are corrected. All turn-off and turn-on service charges shall be made applicable to the consumer.

#### **8.5 Non-Potable Water Supply**

On properties with an auxiliary water supply other than reclaimed reuse water supply as stated in 5.4, the public water system shall be protected by an approved air-gap separation or an approved reduced pressure principle backflow prevention assembly, or other assembly as approved by the Director of Utility or his designee. The cross connection between the public water system and the auxiliary water supply or any reclaimed water system is prohibited.

#### **8.6 Objectionable, But Not Hazardous**

Water or substance(s) that would be objectionable but not hazardous to health, if introduced into the public water system, shall be protected by an approved double check valve backflow assembly.

## 8.7 Actual or Potential Hazard

Any material dangerous to health, which is handled in such a fashion as to create an actual or potential hazard to the public water system, the public water system shall be protected by an approved air-gap separation or an approved reduced pressure principle backflow prevention assembly.

## 8.8 Facilities Where Backflow Preventions Assemblies Will Be Required

(Source: AWWA Manual of Practice M14)

<u>Description of Cross Connection</u>	<u>Assessment of Hazard</u>	<u>Recommended Assembly at Fixture*</u>
Aspirator (medical)	Health	AVB or PVB
Bedpan Washers	Health	AVB or PVB
Autoclaves	Health	RPBA
Specimen Tanks	Health	AVB or PVB
Sterilizers	Health	AVB or PVB
Cuspidors	Health	AVB or PVB
Lab Bench Equipment	Health	AVB or PVB
Autopsy and Mortuary Equipment	Health	AVB or PVB
Sewage Pump	Health	AG
Sewage Ejectors	Health	AG
Fire-Fighting System (toxic liquid foam concentrate)	Health	RPBA
Connection to Sewer Pipe	Health	AG
Connection to Plating Tanks	Health	RPBA
Irrigation Systems with Chemical Additives or Agents (agriculture)	Health	RPBA
Connection to Salt-Water Cooling System	Health	RPBA
Tank Vats or Other Vessels Containing Toxic Substances	Health	RPBA
Connection to Industrial Fluid Systems	Health	RPBA
Dye Vats or Machines	Health	RPBA
Cooling Towers with Chemical Additives	Health	RPBA
Trap primer	Health	AG
Steam Generators	Non Health	RPBA
Heating Equipment		
Commercial	Non Health	RPBA
Domestic	Non Health	DCVA
Irrigation Systems	Non Health	DCVA, AVB, or PVB
	Health	PVB, RPBA
Swimming Pools		
Public	Non Health	RPBA or AG
Private	Non Health	PVB or AG
Vending Machines	Non Health	RPBA or PVB
Ornamental Fountains	Non Health	DCVA or AVB or PVB

Degreasing Equipment	Non Health	
Lab Bench Equipment	Non Health	AVB or PVB
Hose Bibs	Non Health	AVB
Trap Primers	Non Health	AG
Flexible Shower Heads	Non Health	AVB or PVB
Steam Tables	Non Health	AVB
Washing Equipment	Non Health	AVB
Shampoo Basins	Non Health	AVB
Kitchen Equipment	Non Health	AVB
Aspirators	Non Health	AVB
Domestic, Space-Heating Boiler	Non Health	RPBA
Hospitals, Mortuaries, Clinics, Laboratories	Health	RPBA
Plants using Radioactive Material	Health	RPBA
Petroleum Processing or Storage Facilities	Health	RPBA
Premises where Inspection is Restricted	Health	RPBA
Sewage Treatment Plant	Health	RPBA
Sewage Lift Stations	Health	RPBA
Commercial Laundry	Health	RPBA
Plating or Chemical Plants	Health	RPBA
Docks and Dockside Facilities	Health	RPBA
Food and Beverage Processing Plants	Health	RPBA
Pleasure-Boat Marina	Health	RPBA
Tall Buildings (protection against excessive head of water)	Non Health	DCVA
Steam Plants	Non Health	RPBA
Reclaimed Water Systems*	Health	RPBA

Note: (1) AG = air gap; AVB = atmospheric vacuum breaker; DCVA = double check valve backflow prevention assembly; PVB = pressure vacuum breaker; RPBA = reduced pressure principle backflow prevention assembly; TDUCVA = testable dual check valve assembly.

\*Note: (2) Testable Double check valve assemblies ( DCVA use is limited to individual residential (single family detached dwelling units) properties and is acceptable for reducing risks from potential backflows or cross connections only for individual residential (single family detached dwelling units) properties with on-site reclaimed reuse water spray irrigation systems.

Note: (3) Source-American Water Works Manual 14 & amended.

Note: (4) In all cases an approved physical air gap may take the place of Backflow Prevention Assembly.

In addition, all fire service lines shall have an approved double detector check backflow assembly, except as approved by the Director of Utility or his designee, installed in line and above ground just prior to connection point with public water system. In addition all backflow preventer assemblies and associated piping on dedicated fire lines shall be color coded red. Note: serial number must remain legible.

## **8.9 Actual or Potential Cross Connections**

Any uncontrolled cross connections, either actual or potential, that may represent a health hazard to the public water system shall be protected by an approved air-gap separation or an approved backflow prevention assembly at the service line meter connection.

## **8.10 Restricted Premises (Security)**

Any premises, where security requirements or other prohibitions or restrictions exist and it is impossible or impractical to make a complete in-plant cross connection survey, the public water system shall be protected against backflow or back-siphonage from the premises by the installation of a backflow prevention assembly in the service line meter. In this case, maximum protection will be required. An approved air-gap separation or an approved reduced pressure principle backflow prevention assembly shall be installed in each service to these premises.

## **8.11 Commercial Customers**

- A. Commercial customers shall be required to have a testable approved backflow assembly installed on the customer's side of the potable water meter. This backflow preventer will be defined as the "Primary Backflow Preventer"
- B.. Additional backflow preventers may be recommended for other points in the plumbing system to protect against hazards.
- C. The hazard level will be the determining factor in deciding which type of assembly will be required as the" Primary Backflow Preventer".
  - 1. Sites determined to be high hazard will be required to install a reduced pressure principle backflow assembly
  - 2.. Sites determined to be low hazard will be required to install a double check valve assembly.
  - 3. If the hazard level changes from low to high the double check valve assembly will have to be changed to a reduced pressure principle assembly to protect against the higher hazard.

## **8.12 Residential Consumers**

### **A. Health Hazards**

The type of Primary Backflow Preventer required at a residential site shall depend upon the degree of hazard as determined by the inspection personnel

- 1. An approved reduced pressure principle assembly is required where in the opinion of the inspector a health hazard exists.
- 2. An approved double check valve assembly is required where in the opinion of the inspector a non-health hazard exists.
- 3. Minimum protection for residential sites will require installation of a residential dual check assembly

4. Residential systems shall also include any backflow protecters required by the State Building Codes These include , but are not limited to systems that have irrigation, auxiliary water sources, pumps that increase pressure or potential cross-connections.

## **2 .Education**

It is the responsibility of the water purveyor to provide education to the consumer in the areas of backflow prevention and cross-connection. It is an essential part in the development and maintenance of an effective cross-connection control program.

The program will include:

1. Printed material including brochures, pamphlets, and flyers distributed with bills, at utility sites and special events
2. Video tapes aired on public access television, public meetings and meetings of related community groups
3. Information provided to local media
4. Presentations to community groups.

## **8.13 Tank Filling**

This subsection applies to exterminators, lawn services, landscapers, construction companies or any other bulk chemical or water users. All tanks, tank trucks, and spraying apparatus used to convey chemicals or fluids, of any kind are required to use an air gap as backflow protection when filling said tank, truck, or apparatus with potable water. Filling with potable water at unspecified sites is prohibited. Violation of this subsection will be considered a high health hazard and appropriate procedures from Section 5 will be implemented.

# **SECTION 9 APPROVED BACKFLOW PROTECTION ASSEMBLY**

Any backflow prevention assembly required herein shall be of a model and size approved by Charlotte County Utilities'. The term (Approved Backflow Prevention Assembly) shall mean an assembly that has been manufactured in full conformance with the standards established by the American Water Works Association entitled:

AWWA C510-97 and AWWA C511-97 Standards for Double Check Valve and Reduced Pressure Principle Backflow Prevention Assemblies. A testable Double Check Valve may be used in areas served by reclaimed water.

Backflow Prevention Assemblies must be approved by and have the laboratory and field performance specifications of the Foundation for Cross Connection Control and Hydraulic Research of University of Southern California. A testable Double check valve assembly or higher as approved by FDEP, may be used in areas served by reclaimed water.

# SECTION 10 REPAIRS AND TESTING

## 10.1 Testing of Backflow Assemblies

It shall be the duty of the customer at any premises, where backflow prevention assemblies are installed, to have certified inspections and operational tests made at least once per year at the consumer's expense. The responsibility for the cost of installation, relocation, repair, maintenance and replacement for backflow assemblies shall remain with the owner. In those instances where Charlotte County Utility deems the hazard to be exceptional, additional certified inspections may be required at more frequent intervals. Inspections and tests shall be performed by a certified tester performed by Charlotte County Utilities Department at the expense of the owner.

Testing -The first annual testing shall be performed at the time of installation. Subsequent annual tests of the backflow prevention assembly shall be performed at the customers' expense by certified inspectors. Testing requires a water shutdown usually lasting approximately twenty minutes. For facilities that require an uninterrupted supply of water, and when it is not possible to provide water service from two separate meters, provisions shall be made for "a parallel installation of backflow prevention assemblies". During

testing, one assembly remains on-line while the other is being tested. Charlotte County Utilities will not accept an unprotected by-pass when the assembly needs testing, repair or replacement.

## 10.2 Repairs of Backflow Assemblies

If deficiencies are noted during the test, such assemblies shall be repaired or replaced at the expense of the customer. Records of such tests and repairs shall be furnished to and be maintained by Charlotte County Utilities.

## 10.3 Records and Reports

Copies of all test reports, repair summaries, or other communications relating to this cross connection control program, shall be kept by the Director of Charlotte County Utilities for a period of not less than ten (10) years. (Ref.: F.A.C. Chapter 62-550.720).

## 10.4 Repairs—All repairs shall be performed by:

- a. A licensed plumbing contractor or an employee of a licensed plumbing contractor meeting all the license, requirements of Charlotte County.
- b. A State licensed Fire Sprinkler contractor meeting all current State and local licensing requirements working within the confines of a fire line water service, fire sprinkler system, or any part of a fire system governed by the license holder.
- c. An employee of a water purveyor working within the confines of that purveyors' utility.

All persons indicated above must also maintain testing and repair certification requirements through a recognized State of Florida organization such as the University of Florida Center for Training, Research & Education for Environmental Occupations (TREEO) or Florida Water and Pollution Control Operators Association (FWPCOA).

## 10.5 Test Failure

The owner of a backflow prevention assembly that fails a test or does not meet the standards of this ordinance shall have the backflow device repaired or altered to meet these standards within thirty (30) days of the “date of the test/inspection report.

# SECTION 11 INSTALLATION

## 11.1 Installation Guidelines for Backflow Prevention Assemblies

All backflow prevention assemblies shall be installed in accordance with the manufacturer’s installation instructions, and the following Charlotte County Utilities guidelines. Standard Drawings in the Appendix B will further depict installation of specific backflow prevention assemblies.

- A. Pipe lines shall be thoroughly flushed to remove foreign material and debris before installing the assembly.
- B. If not already provided, approved shut off valves should be installed at each end of the assembly for testing and servicing purposes.
- C. The assembly shall be placed in the horizontal position unless otherwise specified by manufacturer’s instructions and authorized by Charlotte County Utilities.
- D. The assembly shall always be installed in an accessible location to facilitate testing and servicing.
- E. Unless otherwise approved by the Director of Utilities or his designee the assembly shall always be installed with lowest point a minimum of 12 inches above ground, maximum flood level for reduced pressure principal and double check valve assemblies, or one (1) foot above the highest outlet for pressure vacuum breakers.
- F. The assembly shall be adequately supported to prevent the assembly from sagging.
- G. The assembly shall meet the standards of the University of Southern California Foundation for Cross Connection Control Hydraulic Research or the Standard Plumbing Code and AWWA Standards.
- H. If the assembly is to be painted the identification information must be protected so as to remain readable , which is essential to accurate record keeping.

## 11.2 Location of Backflow Assembly

The location of the backflow assembly adjacent to the Water Service Meter may create a hazardous situation. This location could also make complying with the installation specifications unnecessarily difficult and expensive. If this occurs a variance may be requested and granted for a change in the location of the backflow assembly. The authorization by the director or his designee shall be in written form and applies only to the assembly in question.

## **SECTION 12 RECLAIMED WATER**

### **12.1 Supply**

Reclaimed water fire hydrants shall be served only by reclaimed water. There will be no connections between reclaimed water and potable water, or auxiliary water.

### **12.2 Blow-Offs**

Reclaimed water blow-offs shall be located below grade level and installed in a locking cast iron vault for safety.

### **12.3 Reclaimed Water Fire Protection Sprinkler Systems**

Reclaimed water fire protection sprinkler systems shall be color coded purple to differentiate between potable water systems and there shall be no connection between the reclaimed water sprinkler system and the potable water system.

### **12.4 Reclaimed Water Irrigation Specifications**

- a. Cross Connections to the potable water system are prohibited.
- b. Reuse facilities shall be color coded or marked. Underground piping which is not manufactured of metal shall be color coded using Pantone Purple 522C using light stable colorants. Underground metal pipe shall be color coded or marked using purple as the predominant color.
- c. Reclaimed water shall not be used to fill swimming pools, hot tubs, or wading pools.
- d. Low trajectory nozzles, or other means to minimize aerosol formation.
- e. A setback distance of 100 feet shall be maintained from indoor aesthetic features using reclaimed water to adjacent indoor public eating and drinking facilities.

### **12.5 Wells and Prohibited Connections**

- a. All wells on properties served by reclaimed reuse water shall be protected by a reduced pressure principal backflow assembly or abandoned according to South Florida Water Management District regulatory requirements.
- b. The interconnection of the reuse transmission, distribution, or on-site irrigation system with any non-potable water supply is prohibited.
- c. The connection of any on-site or off-site potable and/or non-potable water system with/or through the reuse irrigation systems is prohibited.

## 12.6 Cross-Connection Procedure (Health Hazard)

If a cross-connection between the potable and reclaimed water is discovered the representatives of Charlotte County Utilities shall:

Immediately discontinue potable water and/or reclaimed water service to the affected area.

1. If the potable water system is contaminated, clear the potable water lines.
2. Eliminate the cross-connection.
3. Test the affected area for other possible cross-connections.
4. Within 24 hours, notify the South District Office's domestic wastewater and drinking Water programs
5. Within 5 days of discovery of a cross-connection. Submit a written report to the Department detailing: a description of the cross-connection, how the cross-connection was discovered, the exact date and time of the discovery, approximate time that the cross-connection existed, the location, the cause, steps taken to eliminate the cross-connection, whether reclaimed water was consumed, and reports of possible illness, whether the drinking water system was contaminated and the steps taken to clear the drinking water system, when the cross-connection was eliminated, plan of action for testing for other possible cross-connections in the area, and an evaluation of the cross-connection control and inspection program to insure that future cross-connections do not occur.

## SECTION 13 THERMAL EXPANSION

### 13.1 Thermal Expansion

Backflow preventers can create hazardous conditions by preventing the backflow of water from water heaters or any other types of equipment that create back pressure. According to plumbing regulations, all water heaters are required to have Temperature and Pressure valves ( T and P ). The piping inside of a customer's facility or house is considered a closed system whenever a working backflow prevention device or assembly is installed in the main service.

### 13.2 Testing

All Temperature and Pressure valves should be tested annually by exercising the valve according to manufacturer's instructions.

### **13.3 Symptoms of Thermal Expansion**

1. The T and P valve drips during any recovery cycle in which no hot or cold water is being used
2. Hot water pipes creak or make noise while heater is recovering and all valves are closed.
3. Water surges when a valve is opened and then pressure drops.
4. Faucets start to drip when heater is operating and no water is being used.
5. Water heaters , storage tanks or other components of the water supply system fail prematurely.
6. A metallic creaking noise might actually be heard in the location of the heater as the pressure is relieved and the stretched tank returns to a natural shape.

### **13.4 Expansion Tanks**

An expansion tank may be installed on an existing piping system to supply additional protection from thermal expansion.

# Appendix A

# CHARLOTTE COUNTY UTILITIES TEST AND MAINTENANCE REPORT

CUSTOMER: \_\_\_\_\_ METER NUMBER \_\_\_\_\_

STREET ADDRESS: \_\_\_\_\_

MAILING ADDRESS: \_\_\_\_\_

LOCATION OF ASSEMBLY: \_\_\_\_\_

TYPE OF ASSEMBLY:      RP       DC       PVB       SVB       SIZE: \_\_\_\_\_

MANUFACTURER: \_\_\_\_\_ MODEL: \_\_\_\_\_ SERIAL NO: \_\_\_\_\_

GAUGE MANUF \_\_\_\_\_ SERIAL # \_\_\_\_\_ DATE CALIBRATED: \_\_\_\_\_

Check Valve #1	Relief Valve	Check Valve #2	Pressure Vacuum Breaker
<input type="checkbox"/> leaked or <input type="checkbox"/> closed tight	opened at: _____ psi or did not open <input type="checkbox"/>	<input type="checkbox"/> leaked or <input type="checkbox"/> closed tight	<b>Air Inlet:</b> did not open <input type="checkbox"/> or opened at _____ psi
differential pressure across check valve _____ psi	<b>Outlet shut-off valve:</b> <input type="checkbox"/> leaked <input type="checkbox"/> closed tight	<b>OPTIONAL TEST</b> differential pressure across check valve _____ psi	<b>Check Valve:</b> leaked <input type="checkbox"/> or held at _____ psi
<input type="checkbox"/> cleaned only Replaced: rubber kit <input type="checkbox"/> CV assembly <input type="checkbox"/> or disc <input type="checkbox"/> O-rings <input type="checkbox"/> Seat <input type="checkbox"/> spring <input type="checkbox"/> stem/guide <input type="checkbox"/> retainer <input type="checkbox"/> lock nuts <input type="checkbox"/> Other <input type="checkbox"/>	<input type="checkbox"/> RV cleaned only Replaced: RV rubber kit <input type="checkbox"/> RV assembly <input type="checkbox"/> or disc <input type="checkbox"/> diaphragm (s) <input type="checkbox"/> seat <input type="checkbox"/> spring <input type="checkbox"/> guide <input type="checkbox"/> O-rings <input type="checkbox"/> Other <input type="checkbox"/>	<input type="checkbox"/> cleaned only Replaced: rubber kit <input type="checkbox"/> CV assembly <input type="checkbox"/> or disc <input type="checkbox"/> O-rings <input type="checkbox"/> seat <input type="checkbox"/> spring <input type="checkbox"/> stem/guide <input type="checkbox"/> retainer <input type="checkbox"/> lock nuts <input type="checkbox"/> Other <input type="checkbox"/>	<input type="checkbox"/> cleaned only Replaced: rubber kit <input type="checkbox"/> CV assembly <input type="checkbox"/> disc, air inlet <input type="checkbox"/> disk, CV <input type="checkbox"/> seat, CV <input type="checkbox"/> spring, air inlet <input type="checkbox"/> spring, CV <input type="checkbox"/> retainer <input type="checkbox"/> guide <input type="checkbox"/> O-rings <input type="checkbox"/> Other <input type="checkbox"/>
differential pressure across check valve _____ psi	Relief valve opened at _____ psi	differential pressure across check valve _____ psi	air inlet _____ psi check valve _____ psi

COMMENTS \_\_\_\_\_

INITIAL TEST \_\_\_\_\_ PASS \_\_\_\_\_ FAIL \_\_\_\_\_ DATE \_\_\_\_\_ TIME \_\_\_\_\_

FINAL TEST \_\_\_\_\_ PASS \_\_\_\_\_ FAIL \_\_\_\_\_ DATE \_\_\_\_\_ TIME \_\_\_\_\_

TESTED BY (PRINT) \_\_\_\_\_ (SIGNATURE \_\_\_\_\_)

CERTIFICATION NUMBER \_\_\_\_\_ EXPIRATION DATE \_\_\_\_\_

COMPANY NAME \_\_\_\_\_

COMPANY ADDRESS \_\_\_\_\_

# NOTICE TO TEST

Date  
Name  
Address

## Dear Sir/Madam

In order to continue to maintain the quality of the Charlotte County's water supply at the highest level possible, backflow preventers are required to be tested on an annual basis. Our records show that your backflow assembly is due to be tested. You are required to have such equipment tested within \_\_\_\_\_ days from the date of this letter. The test should be completed by an individual certified in backflow testing.

Please find attached the "Test and Maintenance Report" form, which must be completed and returned to this office after testing of the backflow assembly. Feel free to contact us if you have any questions. Your cooperation in this matter is greatly appreciated.

Sincerely,

Water Quality Control Coordinator  
25550 Harbor View Road ,Unit 1  
Port Charlotte, Florida 33980  
Charlotte County Utilities  
(941) 764-4595 or (941) 883-3501

**BACKFLOW PREVENTION**  
**FIRST NOTICE OF VIOLATION**

IN THE MATTER OF:

CUSTOMER

ADDRESS

**OWNER**

**DATE**

**LEGAL AUTHORITY**

In accordance with Charlotte County Code Chapter \_\_\_\_\_, you are hereby notified that the above described property is in violation of \_\_\_\_\_, findings are made and notice issued pursuant to the authority vested in the Director of Utilities.

1. Charlotte County Utilities is charged with, application and enforcement of the Backflow Prevention Program.
2. To protect the potable water system, the Charlotte County Utilities administers a Backflow Prevention Program.
3. Upon inspection of this facility's backflow preventer, it was determined that a violation exists.

VIOLATION: \_\_\_\_\_

THEREFORE, BASED ON THE ABOVE FINDINGS, YOU ARE HEREBY NOTIFIED THAT:

4. This facility is in violation of Charlotte County Code Section \_\_\_\_\_
5. This facility was inspected and warned of the violation on \_\_\_\_\_ Facility was re-inspected on \_\_\_\_\_ and violation still exists.
6. You have \_\_\_\_\_ **DAYS** to respond in writing or by telephone call stating what corrective actions will or have been taken.
7. FAILURE TO COMPLY WITH NOTICE MAY RESULT IN A FINE OF UP TO \$1000.00 PER VIOLATION PER DAY. THE FINE MAY BECOME A LIEN UPON YOUR PROPERTY.YOUR FAILURE TO PAY ANY FINE MAY RESULT IN TERMINATION OF SERVICE AND FURTHER LEGAL ACTION. YOU HAVE THE RIGHT TO APPEAL PURSUANT TO SECTION 3-8-167 OF CHARLOTTE COUNTY CODE.

Signed \_\_\_\_\_ Date \_\_\_\_\_

Water Quality Control Coordinator  
Charlotte County Utilities  
Tel #( 941) 764-4595 or (941) 883-3501

# NOTICE TO INSTALL

## Date

Name  
Address

## Dear Sir/Madam

In order to continue to maintain the quality of the Charlotte County's water supply at the highest level possible, backflow preventers are required on all services where the water may come in contact with a contaminant, or where there is the possibility of a cross-connection or backflow. In accordance with local ordinance and state rules, an approved backflow prevention device is required to be installed on the potable water service by a licensed plumber."

You are required to have such equipment installed within \_\_\_\_\_ days from the date of this letter.

Please find attached the "Test and Maintenance Report" form, which must be completed and returned to this office after installation of the backflow assembly, and a list of approved certified backflow prevention assembly testers and installers located in the area.

Feel free to contact us if you have any questions. Your cooperation in this matter is greatly appreciated.

Sincerely,

Water Quality Control Coordinator  
25550 Harbor View Road ,Unit 1  
Port Charlotte, Florida 33980  
Charlotte County Utilities  
(941) 764-4595 or (941) 883-3501

# Appendix B









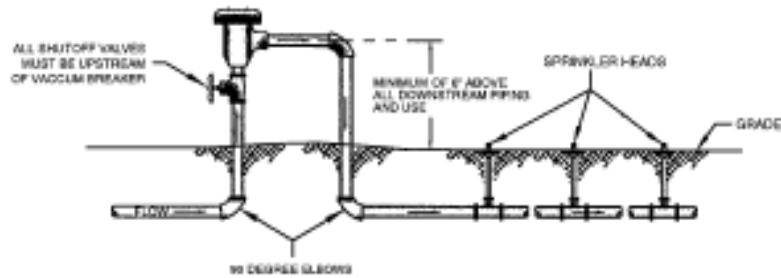

**ATMOSPHERIC VACUUM BREAKER  
TYPICAL INSTALLATION DETAIL**

n.l.s.

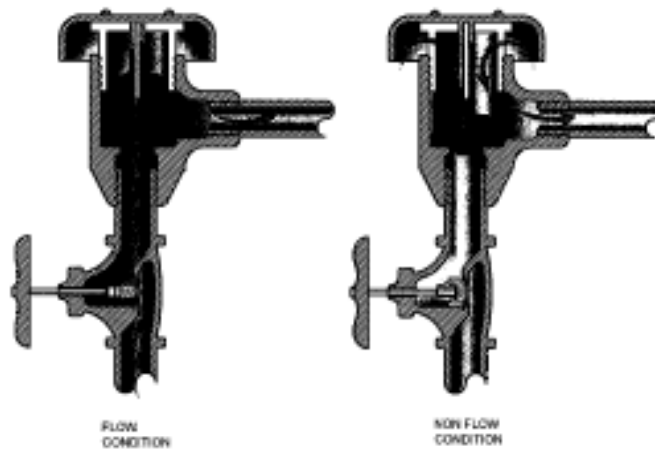

**ATMOSPHERIC VACUUM BREAKER  
TYPICAL FLOW CONDITION  
DETAIL**

n.l.s.

**NOTES:**

1. USE ONLY WITH IRRIGATION SPRINKLER HEADS.
2. INSTALLATION HEIGHT MUST BE 6 INCHES ABOVE THE HIGHEST DOWNSTREAM PIPING OR USAGE POINT.
3. NO VALVE OR SHUT OFF SHALL BE INSTALLED DOWNSTREAM FROM THE ATMOSPHERIC VACUUM BREAKER.

DATE: 3/23/2007	<b>ATMOSPHERIC VACUUM BREAKER</b>	PROVIDED FOR INFORMATIONAL PURPOSES ONLY. NO MODIFICATIONS WITHOUT WRITTEN CCU APPROVAL
DRAWN BY: DJS		PAGE No.
APPROVED BY:		NUMBER: W-20-AVB
<b>CHARLOTTE COUNTY UTILITIES</b>		

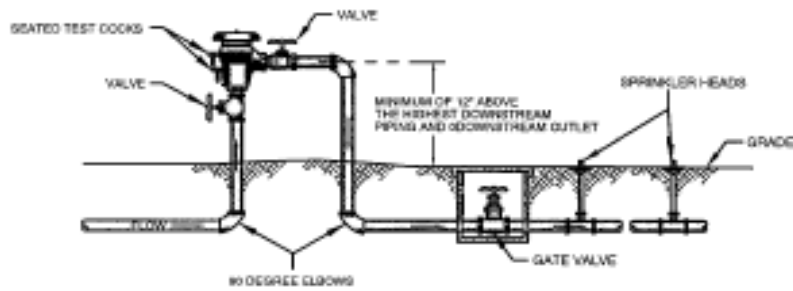

**TYPICAL PRESSURE VACUUM BREAKER  
INSTALLATION DETAIL**

n.i.s.

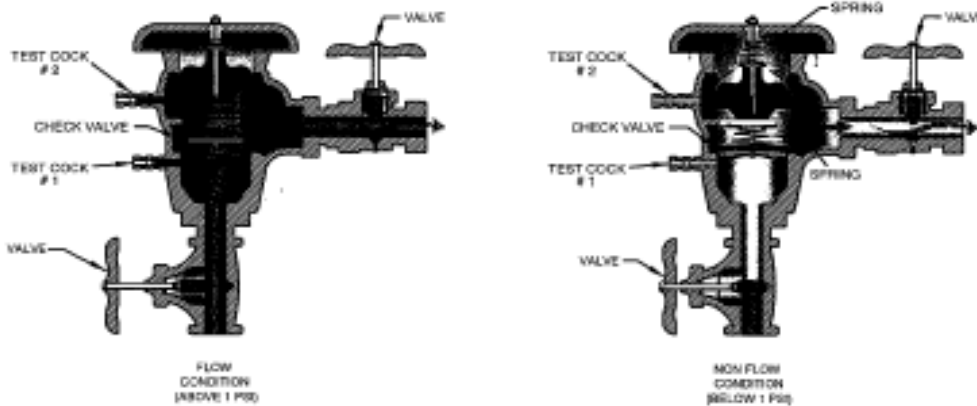

**PRESSURE VACUUM BREAKER  
TYPICAL FLOW CONDITION  
DETAIL**

n.i.s.

**NOTES:**

1. INSTALLATION HEIGHT MUST BE 12 INCHES ABOVE THE HIGHEST DOWNSTREAM PIPING OR OUTLET POINT OF THE ASSEMBLY TO PRECLUDE BACK PRESSURE.
2. ASSEMBLIES MUST NOT BE INSTALLED WHERE BACK PRESSURE COULD OCCUR.

DATE: 3/29/2007	<b>PRESSURE VACUUM BREAKER</b>	PROVIDED FOR INFORMATIONAL PURPOSES ONLY. NO MODIFICATIONS WITHOUT WRITTEN CCU APPROVAL.
DRAWN BY: DJS		PAGE No.
APPROVED BY:		NUMBER: W-21-PVB
<b>CHARLOTTE COUNTY UTILITIES</b>		

